

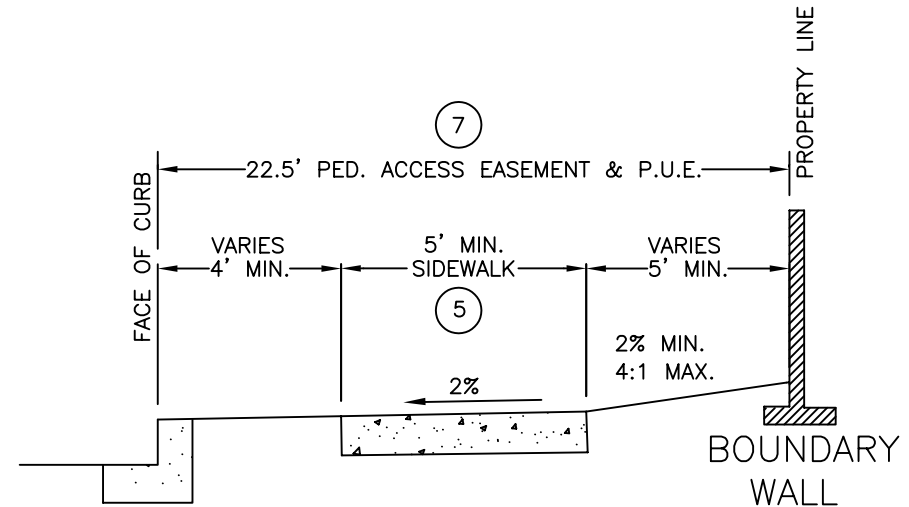

**PLAN**  
SCALE: NONE

**GENERAL NOTES:**

- ① SIDEWALK, CURB AND GUTTER SHALL CONFORM TO CITY STANDARD DRAWING.
- ② BOUNDARY WALL WITH 5' INSETS WILL BE CONSTRUCTED FOR RESIDENTIAL DEVELOPMENTS, AS APPROVED BY THE CITY.
- ③ COMMERCIAL DEVELOPMENTS GENERALLY DO NOT REQUIRE A BOUNDARY WALL.
- ④ CURVE RADII MAY VARY FROM 250' TO 400'.
- ⑤ SIDEWALKS WIDER THAN 5' (MAX. 8') WILL REQUIRE A CORRESPONDING INCREASE IN EASEMENT WIDTH.
- ⑥ GROUND SLOPE AT BOUNDARY WALL SHALL NOT EXCEED 4:1. BERMS MAY BE INSTALLED.
- ⑦ LANDSCAPE AND GRADING PUBLIC IMPROVEMENT PLANS ARE REQUIRED FOR AREA. ALL LANDSCAPING MUST CONFORM TO CITY LANDSCAPE AND IRRIGATION STANDARDS. A COPY OF THESE STANDARDS MAY BE OBTAINED FROM THE RECREATION AND PARKS DEPARTMENT, 419 S. McCLELLAND ST., (805) 925-0951 ext. 260.



**TYPICAL SECTION**  
SCALE: NONE

 RICHARD G. SWEET R.C.E. 44,213 EXP. 6/30/07 REVISIONS BY APP DATE		12/01/05 DATE		<b>City of Santa Maria Standard Drawing</b>	
DRAWN BY: A.G.      DATE DRAWN: 9/98      SCALE: NONE				DESCRIPTION:  <b>MEANDERING SIDEWALK</b>	STANDARD NUMBER <b>RD-14</b>
SHEET 1 OF 1					