

TYPICAL PLAN

SHOWING WATER MAIN LAYOUT, BASIC SIZE & SCHEMATIC LOCATION OF VALVES & FIRE HYDRANTS.
THIS DRAWING IS A DESIGN GUIDELINE ONLY, NOT FOR CONSTRUCTION PURPOSES.

SIZE	DEPTH OF MIN. COVER TO TOP OF PIPE
6"	36"
8"	36"
10"	36"
12"	36"
14"	48"
16"	48"
18"	48"
20"	48"

GENERAL NOTES:

1. MAXIMUM SPACING BETWEEN FIRE HYDRANTS IS 350' FOR MULTIFAMILY, COMMERCIAL & INDUSTRIAL; 400' FOR SINGLE FAMILY RESIDENTIAL.
- 2A. ALL PIPE SIZES 4" THRU 12" TO BE P.V.C., AWWA C900 CLASS 150, DR 18 UNLESS NOTED OTHERWISE.
- 2B. ALL PIPE SIZES 14" THRU 36" TO BE AWWA C905, DR 18 WITH A PRESS. RATING OF 165 PSI, UNLESS NOTED OTHERWISE.
3. WATER MAINS TO BE PLACED 6' HORIZONTALLY FROM NORTH & EAST CURBS.
4. THE NUMBER OF VALVES REQUIRED AT A JUNCTION IS THE NO. OF LEGS LESS ONE, EXCEPT FOR TRANSMISSION LINES WHICH REQUIRE A VALVE AT EVERY LEG OF TEE OR CROSS.
5. ALL DEAD ENDS REQUIRE A FIRE HYDRANT OR A BLOW-OFF (1" MIN. SIZE OR AS PER CITY ENGINEER).
6. FUTURE STREETS AND FUTURE LINES SHALL BE PROVIDED FOR WITH A LEG OF TEE OR CROSS. APPROPRIATE VALVING, FITTINGS, PIPING UNDER PAVEMENT & BLOW-OFF SHALL ALSO BE REQUIRED.
7. DEPTH OF COVER TO BE PER TABLE THIS SHEET.
- 8A. ALL VALVE SIZES FROM 3" TO 12" SHALL BE RESILIENT-WEDGE GATE VALVES, C509 CLOW, WATEROUS, AVK, M&H OR APPROVED EQUAL.
- 8B. ALL VALVE SIZES 14" AND ABOVE SHALL BE RUBBER-SEATED BUTTERFLY VALVES AWWA C504 (MUELLER BRAND LINE SEAL III EPOXY LINED I.D. OR APPROVED EQUAL).
9. ALL VALVES, FITTINGS AND PIPE SHALL BE IN ACCORDANCE WITH CITY STANDARD SPECIFICATION FOR MATERIALS AND THE INSTALLATION OF WATER MAINS.

TYPICAL DETAILS

SHOWING FITTINGS REQUIRED & SIZE. SEE DRWG. FOR PLAN SYMBOLS FOR WATER MAINS AND APPURTENANCES.

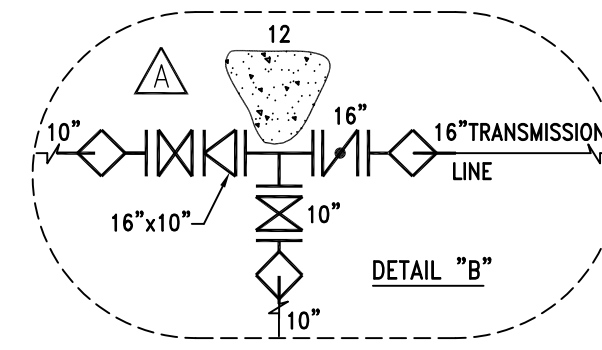
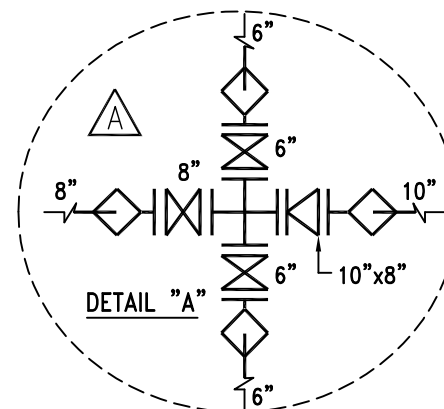
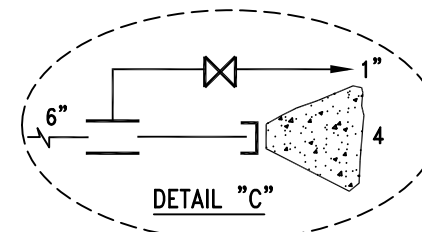

RICHARD G. SWEET R.C.E. 44,213 EXP. 6/30/07		1/20/05		DATE	
REVISIONS		BY	APP	DATE	
A	UTILITY DEPARTMENT REVISIONS	CJP		11/15/12	
DRAWN BY: L.A.D.			DATE DRAWN: 7/69		SCALE: NONE

City of Santa Maria
Standard Drawing

DESCRIPTION:
WATER MAIN LAYOUT WITH FITTING DETAILS

STANDARD NUMBER
WA-11A

SHEET 1 OF 1